

# CWICAR

CLEMSON UNIVERSITY INTERNATIONAL CENTER FOR AUTOMOTIVE RESEARCH



Where innovation gets the green light.



# CU-ICAR

## 10 Business Models

### May 2009

For more information please contact:  
Suzanne Dickerson  
864-283-7119  
[sdicker@clemson.edu](mailto:sdicker@clemson.edu)



## CU-ICAR Overview

- Strong research & development capabilities
- State-of-the-art equipment & facilities
- Flexible
- Customizable for various corporate needs
- Designed to share costs where applicable
- Partnerships or individual relationships
- Varying levels of academic assistance

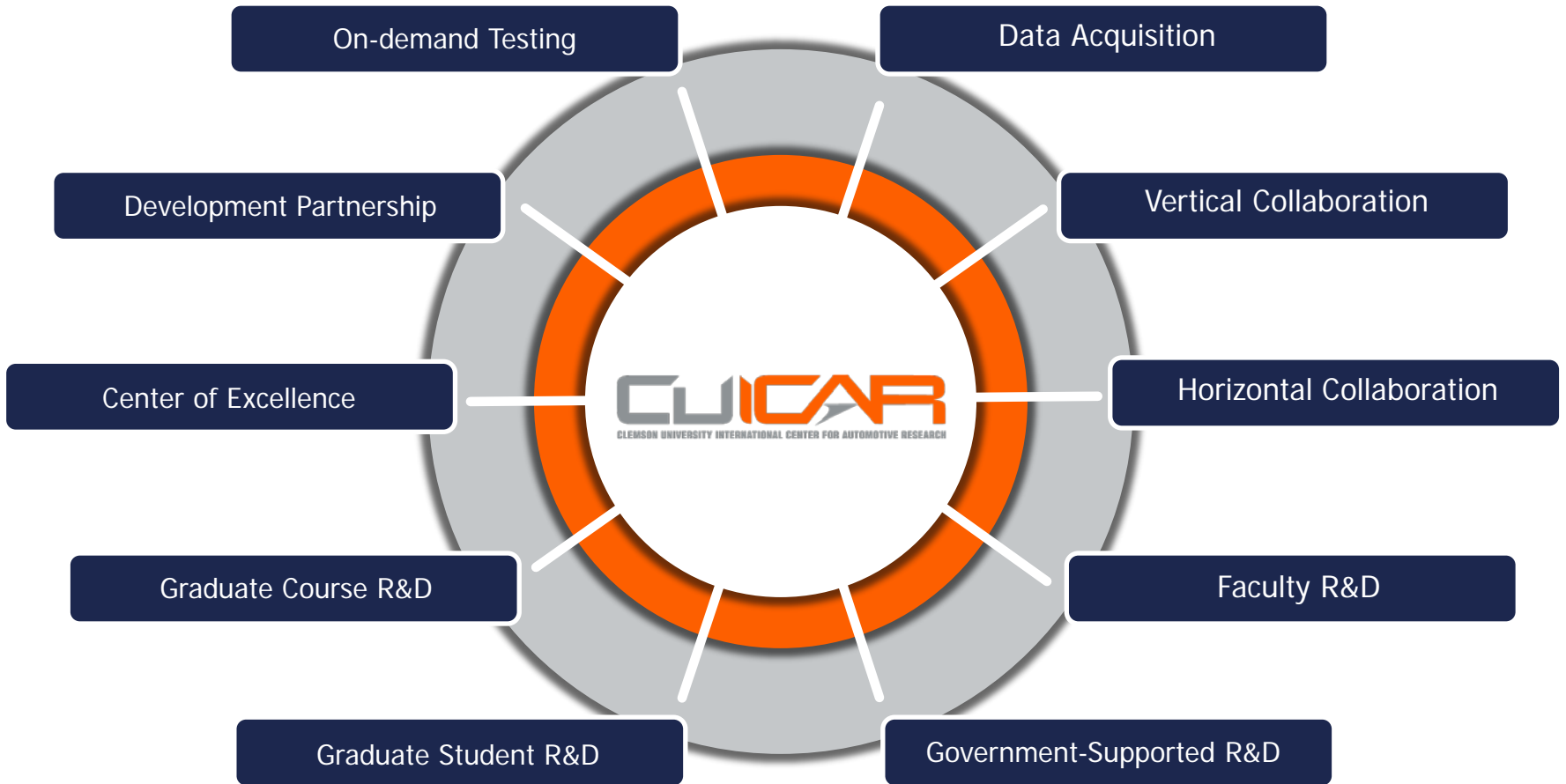

## Business Models



# Model 1 - Data Acquisition

## Application

- Industry collaboration through an independent facility for the purpose of developing & gathering critical testing and data acquisition

## Characteristics

- Participants contribute to equipment purchases
- Participants can come from different industry segments (e.g.: OE suppliers)
- Competitors collaborate towards common objectives
- Research objectives are clearly defined at onset
- Clemson's role: "Neutral Agency"
- No Intellectual property (IP) generated



# Model 1 - Data Acquisition

## Potential Example

### Situation:

- OEMs need additional tire data for vehicle dynamics modeling to comply new stability control regulations
- Tire companies don't want to bear total cost of expensive new equipment required for these tests

### Solution:

- OEMs and tire companies jointly sponsor an independent facility at CU-ICAR that performs these tests on a fee-for-service basis. Clemson personnel may also contribute to future standards development





# Model 2 - Vertical Collaboration

## Application

- Vertically-linked companies work together and combine technologies to achieve separate or similar goals on specific industry objectives

## Characteristics

- Participants may come from different industry segments or even different industries – and bring different technologies to the topic
- Research topic is clearly defined at onset but outcome/objectives are co-developed over time
- Clemson's role: "Collaboration Brokers and Development Partners"
- Intellectual property belongs to individual companies and/or Clemson



# Model 2 - Vertical Collaboration

## Current Example

### Situation:

- Michelin is developing TWEEL technology for implementation in passenger cars with potential to deliver handling advantages without sacrificing ride comfort
- BMW is interested in new technologies that potentially delivery superior driving dynamics with reduced mass and zero-pressure mobility

### Solution:

- Michelin and BMW jointly contract with Clemson to model the ride and handling of a Mini utilizing optimized suspension & TWEEL technology





# Model 3 - Horizontal Collaboration

## Application

- A group of companies with a related (or same) problem/opportunity combine resources and efforts to solve the challenge

## Characteristics

- Participants come from the same industry segments (e.g: suppliers only) and are typically competitors but are working on “pre-competitive” stage topics
- General topic is defined at onset but specific topics and objectives/outcome are co-developed over time
- Clemson’s role: “Teacher/Lead”
- Intellectual property is shared



# Model 3 - Horizontal Collaboration

## Potential Example

Situation:

- Several supplies realize they share a common interest in a generic topic that applies to them all

Solution:

- They create a consortium managed by CU-ICAR that jointly identifies specific projects whose results are equally shared by all





# Model 4 - Faculty R&D

## Application

- Industry companies contract with CU-ICAR faculty that have specific expertise to help solve specific industry problems

## Characteristics

- Single company working with single faculty member or small group of faculty focused on specific industrial problem
- Clemson's role: "Lead/Researcher"
- Intellectual property belongs to Clemson (exclusive license to be negotiated with partner company)



# Model 4 - Faculty R&D

## Current Example

### Situation:

- Timken makes large diameter bearings and needs a more efficient instrument to do in-process metrology of the diameter and cone angles of raceways

### Solution:

- Clemson faculty have specific expertise in developing instruments for precision dimensional metrology. Recognizing the synergy between their needs and the faculty expertise, Timken contracts with that faculty member to develop new prototype instruments

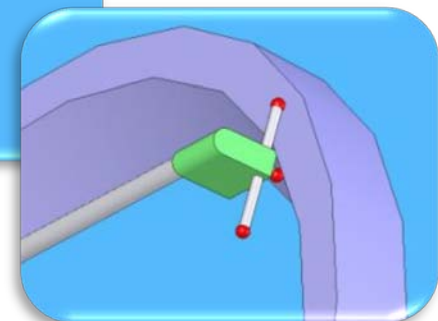
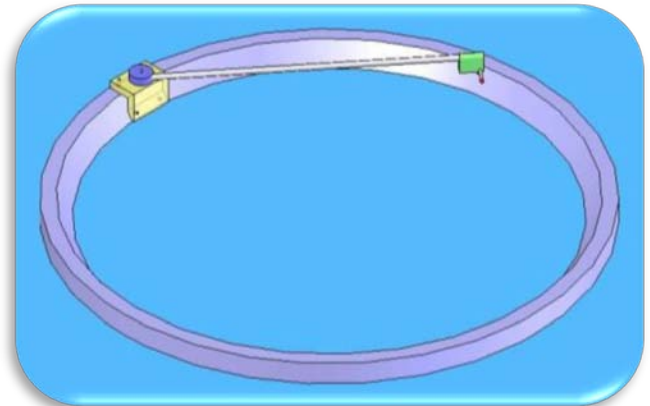



# Model 5 - Government-supported R&D

## Application

- Company or companies work with CU-ICAR to solve specific industry issues supported by government funds/grants (can be a mix of government, grant, corporate funding)

## Characteristics

- Single company (or small group of companies) working with faculty focused on specific industrial problem with the support of government funding.
- Clemson's role: "Lead/Researcher"
- Intellectual property belongs to Clemson (exclusive license to be negotiated with partner company)



# Model 5 - Government-supported R&D

## Current Example

### Situation:

- Michelin is developing TWEEL technology and realizes that TWEELS offer the possibility of significant reduction in rolling resistance, potentially leading to significant reduction in fuel usage.
- In conjunction with Clemson, Georgia Tech and Milliken, Michelin submits a proposal to the NIST ATP program to support research leading to ultra-low rolling resistance TWEELS



### Solution:

- NIST awards Michelin \$2M, which is matched by internal Michelin R&D funds. Michelin subcontracts portions of the research to Clemson, Georgia Tech and Milliken





# Model 6 - Graduate Student R&D

## Application

- Graduate-level students work with/at a company on a specific project for a specified period of time, under the oversight of a professor

## Characteristics

- Student working directly at/with single company for a defined period of time and focused on specific industrial problem
- The student may either be directly employed by the company or by Clemson via contract with the company
- Clemson's role: "Lead/Researcher"
- Intellectual property belongs to Clemson (exclusive license to be negotiated with partner company)



# Model 6 - Graduate Student R&D

## Current Example

### Situation:

- Dale Earnhardt Inc. would like to improve the accuracy with which they fabricate NASCAR COT chassis

### Solution:

- Clemson assigns a graduate student to work on the project at DEI for a specified period of time. A Clemson faculty member oversees the student's activities

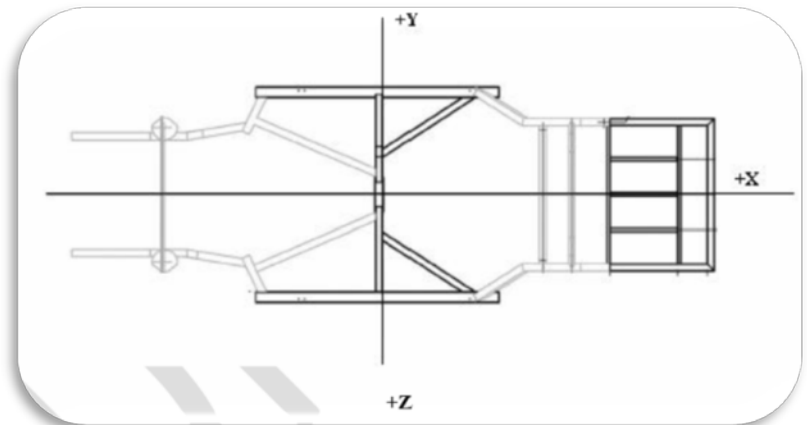



# Model 7 - Graduate Course R&D

## Application

- Specific industry problems are used as the content to create a graduate-level course with the goal of solving or moving closer to the solution of the problem

## Characteristics

- Use of “Capstone” course, where small teams of students work directly on/with single company focused on specific industrial problem
- Faculty coaches advise students but do not take direct responsibility for project direction
- Clemson’s role: “Lead/Researcher”
- Intellectual property belongs to Clemson (exclusive license to be negotiated with partner company)



# Model 7 - Graduate Course R&D

## Current Examples

- **Timken:** Develop a test rig for evaluating engines equipped with roller bearings on the main and connecting rod bearings
- **FEV:** Develop an improved pressure control valve for hydraulic accumulators used in hydraulic hybrid vehicles
- **DiMora Motorcar:** Develop suspension designs for future high performance luxury car



# Model 8 - Center of Excellence

## Application

- Companies work with CU-ICAR (and potentially other partners) to create turn-key manufacturing solutions to industry problems

## Characteristics

- Equipment provided by Clemson
- Competitors using Clemson expertise toward individual objectives
- Participants may come from the same industry segments
- Clemson's role: "Problem-solver"
- Intellectual Property belongs to Clemson (exclusive license to be negotiated with partner companies)



# Model 8 - Center of Excellence

## Potential Example

Situation:

- There is no specific institute for “plastic” manufacturing in the Southeast, but a high demand from several suppliers of plastic automotive parts

Solution:

- Set up a team (work group) with local suppliers for plastic parts with the objective of completing the process chain for an injection molding machine



+



+



+



Manufacturing Quality

Handling Automation

Injection Molding



# Model 9 - Development Partnership

## Application

- Companies used CU-ICAR as a development partner to help research and solve problems through its network of partner companies

## Characteristics

- Participants may come from different industry segments (e.g.: OEMS and suppliers) or even different industries and bring different technologies to the topic
- Research topic is clearly defined at onset but outcome/objectives are co-developed over time
- Clemson's role: "Collaboration Brokers/Development Partners"
- Intellectual property belongs to individual companies/Clemson



# Model 9 - Development Partnership

## Potential Example

Situation:

- Organization or company is looking for a development partner to work on a research project.

Solution:

- Clemson engages faculty resources and partner company to work jointly on project.

Anybody  
Software

Carbon Motors Corporation

SIMPACK



# Model 10 - On-demand Testing

## Application

- Industry companies use CU-ICAR facilities and equipment to perform testing on an on-demand basis, leasing equipment at daily rates supported by CU-ICAR technical staff

## Characteristics

- Participants may come from different industry segments or even different industries and bring different technologies for testing/analysis/data gathering
- Clemson's role: "Facility Provider"
- No intellectual property generated



# Model 10 - On-demand Testing

## Potential Example

Situation:

- OEMs and suppliers are looking for ways to avoid capital-intensive expenditures in their own facilities.

Solution:

- Companies use the CU-ICAR facilities – paying competitive rates for testing/laboratory equipment that is supported by CU-ICAR technical staff.

