

**This is a simplified explanation and NOT to be used for design purposes. Please contact Intersil for details.**

Author: Bob Pearson

## Introduction



The draft text [1] of the high speed extension of the IEEE802.11 Standard specifies Complementary Code Keying (CCK) as the

modulation scheme for 5.5 and 11Mbps data rates in the 2.4GHz band. The new high rate specification is expected to be ratified later this year and radios that implement CCK have already been FCC certified. Two digital signal processing baseband processor (BBP) chips now available from Intersil contain all the functions necessary to implement CCK modulation as specified by the high rate draft 802.11 standard. These baseband processor ICs, the HFA3860B and the HFA3861A achieve Ethernet like data rates in wireless LAN systems operating in the 2.4GHz ISM band. This application note will explain the CCK modulation scheme and describe a HFA3861A based radio architecture that the design engineer can use to implement a high data rate packet based transceiver utilizing CCK modulation.

## Complementary Sequences

The subject of CCK modulation is somewhat esoteric in that it is not found in very many textbooks on digital communications. Hence the need for this application note. CCK has its roots in information theory on the subject of complementary sequences. One of the first known works on the subject was published in 1951 by Marcel J.E. Golay [2]. Golay was concerned with the problem of imaging polychromatic radiation as a spread spectrum in an application of a spectrometer. Golay's paper describes how the properties of a complementary sequence were used to control a series of open and closed slits in a multislit spectrometer. Besides being useful in the spectrometer application, Golay found the complementary sequence to be mathematically appealing and published a later paper [4] in which he described the properties of binary complementary sequences and how to synthesize them. Other authors have published papers on binary and polyphase codes with good correlation properties [4-7]. So exactly what is a complementary sequence and what are some of its important properties? We start with the definition of a binary complementary sequence or code. A binary complementary code is a subset of the more general class of codes known as polyphase codes. The IEEE 802.11 CCK codes are polyphase complementary codes.

The following definition for binary complementary codes is borrowed intact from R. Sivaswamy's "Multiphase Complementary Codes" [8]:

Complementary codes, also referred to as binary complementary sequences or series, comprise a pair of

equal finite length sequences having the property that the number of pairs of like elements with any given separation in one series is equal to the number of pairs of unlike elements with the same separation in the other.

The symmetry described in the above definition is not intuitively obvious but is easily demonstrated by an example. We borrow a pair of complementary sequences from Golay [4]:

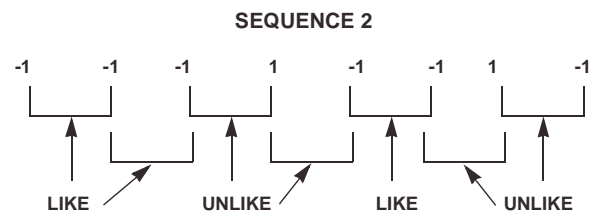
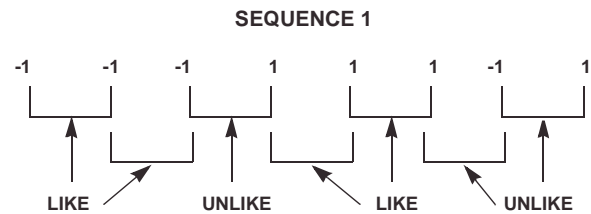

Sequence 1 has 4 pairs of like elements with a separation of 1 and 3 pairs of unlike elements with a separation of 1; whereas Sequence 2 has 4 pairs of unlike elements with a separation of 1 and 3 pairs of like elements. Table 1 summarizes the results of the element pairing for separations of 1, 2 and 3.

**TABLE 1. RESULTS OF ELEMENT PAIRING FOR SEQUENCES 1 AND 2**

PAIR SEPARATION	SEQUENCE 1		SEQUENCE 2	
	LIKE	UNLIKE	LIKE	UNLIKE
1	4	3	3	4
2	4	3	3	4
3	1	5	5	1

We have seen that complementary codes possess a deep seated symmetry. So how does that property make them useful in digital communications? It turns out that complementary codes are characterized by the property that their periodic autocorrelative vector sum is zero everywhere except at the zero shift. This is the property that makes complementary codes useful in digital communications systems. Given a pair of complementary sequences with a<sub>i</sub>

and  $b_i$  elements, where  $i = 1, 2, \dots, n$ , the respective autocorrelative series are given by:

$$c_j = \sum_{i=1}^{n-j} a_i a_{i+j} \quad \text{and} \quad d_j = \sum_{i=1}^{n-j} b_i b_{i+j} \quad (\text{EQ. 1})$$

Ideally, the two sequences  $\{a_i\}$  and  $\{b_i\}$  are complementary if  $c_j + d_j = 0 \quad j \neq 0$

and  $c_0 + d_0 = 2n$ .

Where  $n$  is the length of the code word.

In practice it is difficult to achieve the ideal condition but good codes will have one main peak with minimum residual peaks.

Let's test sequences 1 and 2 for the autocorrelative property of two binary complementary codes. Table 2 is a tabulation of the autocorrelation functions for sequences 1 and 2. The autocorrelation function is the result of the autocorrelation over all bit shifts of the codes. This is analogous to computing the autocorrelation of a digital signal over all phase shifts of the signal. In Table 2 the  $c_j$  and  $d_j$  terms represent the difference between the number of agreements and disagreements between the shifted and unshifted codes. For the zero shift  $c_j$  and  $d_j$  are a maximum, i.e., 8. For all other shifts the  $c_j$  and  $d_j$  terms are minimized and

$$c_j + d_j = \begin{cases} 0 & j \neq 0 \\ 2n & j = 0 \end{cases}$$

So our two sequences are indeed characterized by the autocorrelative property for binary complementary codes.

Besides the autocorrelative property of binary complementary codes there are a number of other properties that are useful in synthesizing sets of complementary codes. The interested reader can check references [4] - [9] for methods of generating complementary codes.

### Polyphase Codes

Now that we have described a binary complementary code pair, let's consider polyphase complementary codes. The binary complementary code was merely a binary sequence having complementary properties. Likewise a polyphase complementary code is a sequence having complementary properties, the elements of which have phase parameters. For example a polyphase code could contain elements having four different phases. The code set defined in the IEEE 802.11 high rate draft standard is a complex complementary code set. That is to say its elements  $a_i$  are a member of the set of complex numbers  $\{1, -1, j, -j\}$  and the code set is characterized by the autocorrelative property described previously for binary codes. In addition, the IEEE 802.11 codes have been shown to possess good Euclidean distance properties for yielding low bit error rates in multipath environments [10].

TABLE 2. TABULATION OF AUTOCORRELATION FUNCTIONS FOR A PAIR OF COMPLEMENTARY CODES

SHIFT	SEQUENCE 1									$c_j$	SEQUENCE 2									$d_j$	$c_j + d_j$
	CODE										CODE										
0	-1	-1	-1	1	1	1	-1	1		8	-1	-1	-1	1	-1	-1	1	-1		8	16
	-1	-1	-1	1	1	1	-1	1			-1	-1	-1	1	-1	-1	1	-1			
1	-1	-1	-1	1	1	1	-1	1		0	-1	-1	-1	1	-1	-1	1	-1		0	0
	1	-1	-1	-1	1	1	1	-1			-1	-1	-1	-1	1	-1	-1	1			
2	-1	-1	-1	1	1	1	-1	1		0	-1	-1	-1	1	-1	-1	1	-1		0	0
	-1	1	-1	-1	-1	1	1	1			1	-1	-1	-1	-1	1	-1	-1			
3	-1	-1	-1	1	1	1	-1	1		-4	-1	-1	-1	1	-1	-1	1	-1		+4	0
	1	-1	1	-1	-1	-1	1	1			-1	1	-1	-1	-1	-1	1	-1			
4	-1	-1	-1	1	1	1	-1	1		0	-1	-1	-1	1	-1	-1	1	-1		0	0
	1	1	-1	1	-1	-1	-1	1			-1	-1	1	-1	-1	-1	-1	1			
5	-1	-1	-1	1	1	1	-1	1		-4	-1	-1	-1	1	-1	-1	1	-1		+4	0
	1	1	1	-1	1	-1	-1	-1			1	-1	-1	1	-1	-1	-1	-1			
6	-1	-1	-1	1	1	1	-1	1		0	-1	-1	-1	1	-1	-1	1	-1		0	0
	-1	1	1	1	-1	1	-1	-1			-1	1	-1	-1	1	-1	-1	-1			
7	-1	-1	-1	1	1	1	-1	1		0	-1	-1	-1	1	-1	-1	1	-1		0	0
	-1	-1	1	1	1	-1	1	-1			-1	-1	1	-1	-1	1	-1	-1			

### CCK Modulation

So much for the primer on complementary codes. Now let's see how the IEEE Standard 802.11 code set is used to modulate a digital waveform. Since the direct sequence spread spectrum (DSSS) technique is used for the high rate modulation scheme, the complementary codes defined in the draft standard are referred to as spreading codes because they are used to spread the occupied bandwidth of the DSSS waveform. Bandwidth spreading and despreading is the basis for obtaining processing gain in DSSS systems. See application note AN9820 for more on bandwidth spreading and processing gain. For now let's stick to the subject of CCK modulation as defined by the 802.11 draft standard.

The IEEE 802.11 complementary spreading codes have a code length 8 and a chipping rate of 11 Mchip/s. The 8 complex chips comprise a single symbol. By making the symbol rate 1.375 MS/s the 11Mbps waveform ends up occupying the same approximate bandwidth as that for the 2Mbps 802.11 QPSK waveform thereby allowing for 3 non-overlapping channels in the ISM band. This is important for maximizing aggregate system throughput in a wireless LAN network and was one reason for choosing CCK as the modulation technique. The 8-bit CCK code words are derived from the following formula:

$$c = \left\{ \begin{matrix} e^{j(\varphi_1 + \varphi_2 + \varphi_3 + \varphi_4)}, & e^{j(\varphi_1 + \varphi_3 + \varphi_4)}, & e^{j(\varphi_1 + \varphi_2 + \varphi_4)}, \\ e^{j(\varphi_1 + \varphi_4)}, & e^{j(\varphi_1 + \varphi_2 + \varphi_3)}, & e^{j(\varphi_1 + \varphi_3)}, & -e^{j(\varphi_1 + \varphi_2)}, & e^{j\varphi_1} \end{matrix} \right\} \quad (\text{EQ. 2})$$

where C is the code word with LSB first to MSB last. This strange looking formula is used to generate the code sets for both 11 and 5.5Mbps data rates. Thus a subset of the 11Mbps code set is used at the 5.5Mbps data rate. The parameters  $\varphi_1 - \varphi_4$  determine the phase values of the complex code set and are defined in the 802.11 high rate standard. For the 11Mbps data rate each symbol represents 8 bits of information. At 5.5Mbps 4 bits per symbol are transmitted. For the purpose of this discussion the 11Mbps mode will be described. Referring to Figure 3, in the transmit mode a serial bit stream is fed to the HFA3861A baseband processor via the HFA3841 MAC. The data bit stream is partitioned into bytes as (d7, d6, d5, ..., d0) where d0 is the LSB and is first in time. The 8 bits are used to encode the phase parameters  $\varphi_1 - \varphi_4$  according to scheme shown in Table 3. The encoding is based on differential QPSK modulation as specified in Table 4.

TABLE 3. PHASE PARAMETER ENCODING SCHEME

DIBIT	PHASE PARAMETER
(d1, d0)	$\varphi_1$
(d3, d2)	$\varphi_2$
(d5, d4)	$\varphi_3$
(d7, d6)	$\varphi_4$

TABLE 4. DQPSK MODULATION OF PHASE PARAMETERS

DIBIT ( $d_{i+1}, d_i$ )	PHASE
00	0
01	$\pi$
10	$\pi/2$
11	$-\pi/2$

Let's use an example to see how a typical code word is generated. Assume the 11Mbps mode and a data bit stream given as d7, d6, d5, ..., d0 = 1 0 1 1 0 1 0 1. Thus from Table 4 d1, d0 = 01 so  $\varphi_1 = \pi$ . In a similar manner d3, d2 = 01 so  $\varphi_2 = \pi$  d5, d4 = 11 so  $\varphi_3 = -\pi/2$  d7, d6 = 10 and  $\varphi_4 = \pi/2$

Substituting the phase parameter values into the code word formula we have:

$$c = \left\{ e^{j(\pi + \pi - \pi/2 + \pi/2)}, e^{j(\pi - \pi/2 + \pi/2)}, e^{j(\pi + \pi + \pi/2)}, -e^{j(\pi + \pi/2)}, e^{j(\pi + \pi - \pi/2)}, e^{j(\pi - \pi/2)}, -e^{j(\pi + \pi)}, e^{j(\pi)} \right\}$$

$$c = \left\{ e^{j2\pi}, e^{j\pi}, e^{j\frac{5\pi}{2}}, -e^{j\frac{3\pi}{2}}, e^{j\frac{3\pi}{2}}, e^{j\pi/2}, -e^{j2\pi}, e^{j\pi} \right\}$$

By Euler's formula we have:

$$e^{j\theta} = \cos \theta + j \sin \theta$$

$$c = \left\{ \cos 2\pi + j \sin 2\pi, \cos \pi + j \sin \pi, \cos \frac{5\pi}{2} + j \sin \frac{5\pi}{2}, -\cos \frac{3\pi}{2} - j \sin 3\pi/2, \cos \frac{3\pi}{2} + j \sin \frac{3\pi}{2}, \cos \frac{\pi}{2} + j \sin \pi/2, -\cos 2\pi - j \sin 2\pi, \cos \pi + j \sin \pi \right\}$$

and so our complex code word is

$$c = \{1, -1, j, j, -j, j, -1, -1\}$$

Now let's see how the HFA3861A baseband processor uses the code word to modulate a carrier and spread the bandwidth of the waveform. Referring to Equation 2, we see that phase parameter  $\varphi_1$  is contained in all 8 chips of the code word so it essentially rotates the whole vector. This is important in the circuit implementation of the CCK modulation as we shall see.

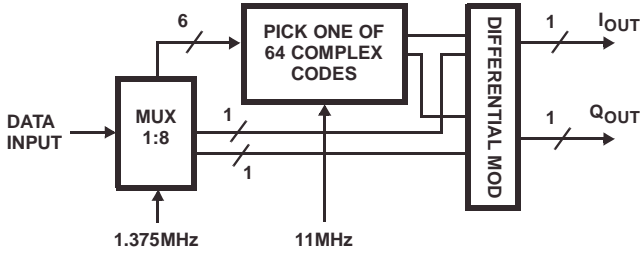

FIGURE 1. BLOCK DIAGRAM OF HFA3861A MODULATOR CIRCUIT

Figure 1 shows the block diagram of the CCK modulator circuit. The output of the HFA3861A data scrambler is partitioned into bytes and fed to a serial in parallel out mux circuit that gets clocked at the symbol rate of 1.375MHz. Six bits of the mux output are used to select one of 64 complex codes which are fed to a differential modulator circuit. The other 2 bits of the mux output are used to QPSK modulate, i.e., rotate, the 8 chip complex code word. The outputs of the differential modulator are the I and Q outputs in accordance with Equation 2 for generating complex codes. And that is essentially CCK modulation in a nutshell.

In the receiver the CCK modulated waveform is converted from analog to digital form after downconversion. Figure 2 shows the demodulator circuit of the HFA3861A.

Demodulation of the CCK modulated signal is done coherently in the HFA3861A baseband processor by a RAKE receiver implementation which features a channel matched filter and Fast Walsh Transform block. A bank of 64 correlators followed by a biggest picker circuit determines which code was transmitted giving 6 bits of the data word (in the 11Mbps mode). The other 2 bits of the 8-bit data word are determined from the QPSK phase of the symbol. Figure 3 shows the HFA3861A baseband processor in the 11Mbps PRISM II radio block diagram. This highly integrated radio features the use of Si Ge process technology in the RF/IF front section, low power consumption, Ethernet like data rates, low cost, reduced bill of materials content, reduced manufacturing costs and improved packet error rate performance in a multipath environment when compared to Intersil's first generation 11Mbps radio based on the HFA3860B baseband processor.

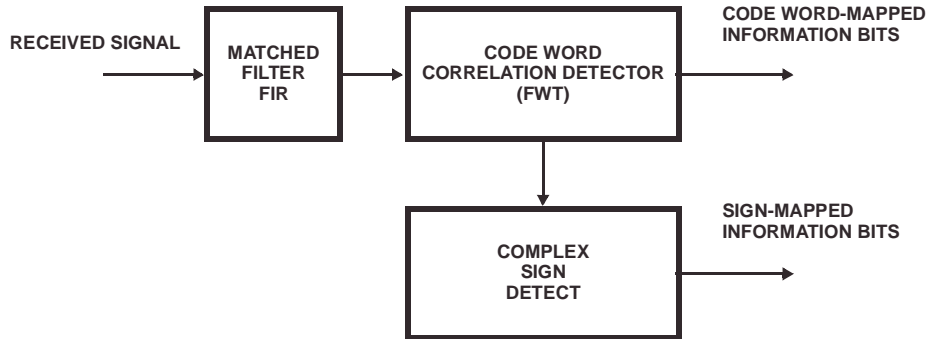

FIGURE 2. HFA3861A RAKE RECEIVER

### Conclusions

Complementary codes and CCK modulation as adopted the IEEE in the 802.11 draft standard have been described. A new baseband processor from Intersil, the HFA3861A, implements the CCK waveform to achieve Ethernet data rates over wireless links. The new baseband processor features improved packet error rate performance in multipath environments through the use of a RAKE receiver architecture.

### Bibliography

- [1] Andren, C. and Boer, J., "Draft Text for the High Speed Extension of the Standard", doc: IEEE P802.11-98/314
- [2] Golay, M.J.E., "Static Multislit Spectrometry and It's Application to the Panoramic Display of Infrared Spectra", J. Opt. Soc. Am, Vol. 41, No. 7, p.468-472; July 1951.
- [3] Golay, M.J.E., "Multislit Spectrometry", J.Opt. Soc. Am, Vol. 39, p.437; 1949
- [4] Golay, M.J.E, "Complementary Series", IRE Trans. On Information Theory, April 1961, p.82-87
- [5] Heimiller, R.C., "Phase Shift Codes with Good Periodic Correlation Properties", IRE Trans. on Information Theory, October 1961, p.254-257.
- [6] Frank, R.L., "Polyphase codes with Good Nonperiodic Correlation Properties", IEEE Trans. on Information Theory, January 1963, p.43-45.
- [7] Welti, G.R., "Quaternary Codes for Pulsed Radar", IRE Trans. on Information Theory, June 1960, p.400-408.
- [8] Sivaswamy, R., "Multiphase Complementary Codes", IEEE Trans. on Information Theory, vol. IT-24, No. 5 Sept. 1978, p.546-552.
- [9] Tseng, C.C. and Liu, C.L., "Complementary Sets of Sequences", IEEE Trans. on Information Theory, vol. IT-18, No. 5, September 1972.
- [10] Halford, K., Halford, S., Webster, M., and Andren, C., "Complementary Code Keying for RAKE-based Indoor Wireless Communication," Proceedings of the 1999 IEEE International Symposium on Circuits and Systems.
- [11] *HFA3861A Data Sheet*, Intersil Corporation, Doc. No. 4776.
- [12] Andren, C. and Webster, M., "CCK Modulation Delivers 11Mbps for High Rate 802.11 Extension", Wireless Symposium/Portable By Design Conference Proceedings, Spring 1999.

All Intersil products are manufactured, assembled and tested utilizing ISO9000 quality systems. Intersil Corporation's quality certifications can be viewed at [www.intersil.com/design/quality](http://www.intersil.com/design/quality)

---

*Intersil products are sold by description only. Intersil Corporation reserves the right to make changes in circuit design, software and/or specifications at any time without notice. Accordingly, the reader is cautioned to verify that data sheets are current before placing orders. Information furnished by Intersil is believed to be accurate and reliable. However, no responsibility is assumed by Intersil or its subsidiaries for its use; nor for any infringements of patents or other rights of third parties which may result from its use. No license is granted by implication or otherwise under any patent or patent rights of Intersil or its subsidiaries.*

---

For information regarding Intersil Corporation and its products, see [www.intersil.com](http://www.intersil.com)

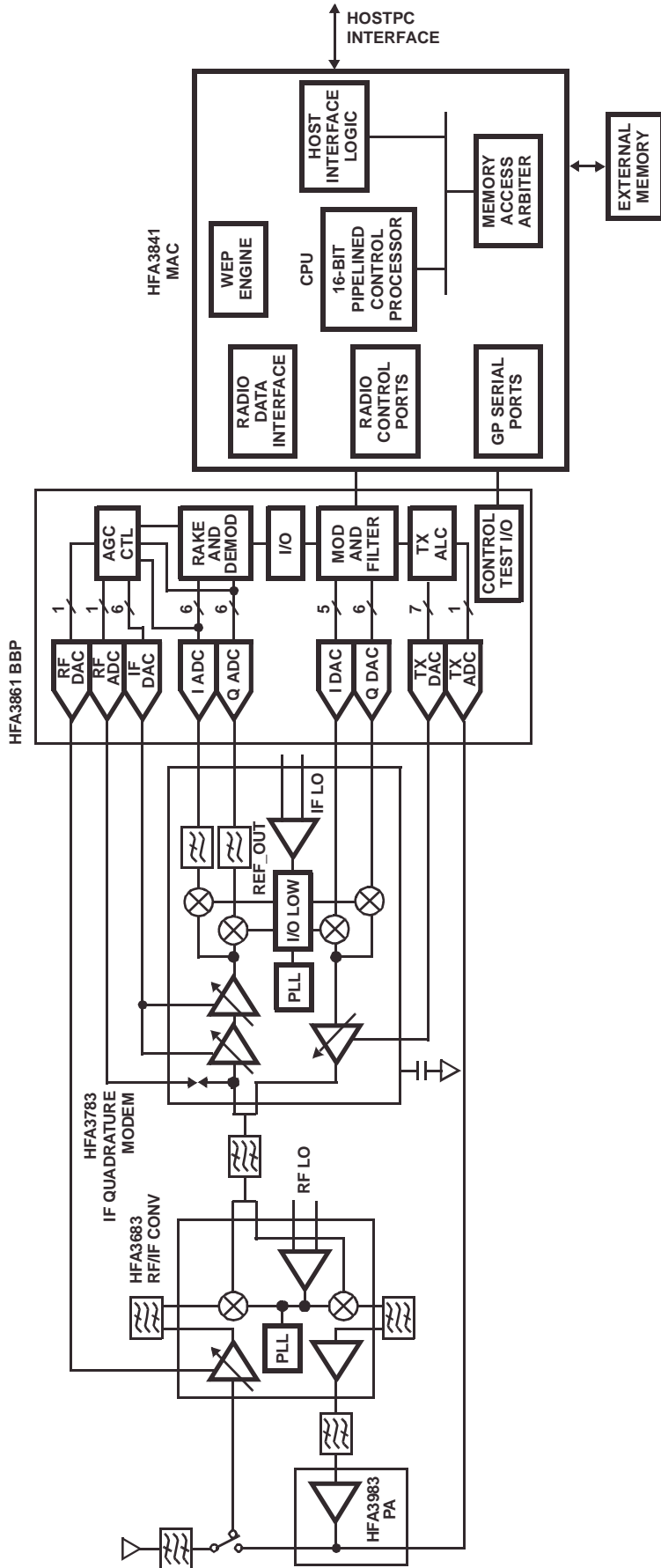

FIGURE 3. PRISM II RADIO BLOCK DIAGRAM